

Smartest | Most Reliable | 12 Years Warranty | Automatic Dual Mode

The QUAD-DM 2000 revolutionizes solar energy solutions with four individual DC input channels, maximizing energy harvest.

It facilitates independent peak power tracking for up to four PV Panels, ensuring optimal performance in grid-tied and Standby mode operation.



Four PV Panels, One Inverter

The QUAD-DM 2000 microinverter uses patented technologies that eliminate the use of short-life electrolytic capacitors, providing high reliability, and a 25-year Product life. Based on a Per-Watt rating, the QUAD-DM 2000 has the lowest microinverter cost, the highest power output, the highest power density, and the lowest weight in the industry.

Salient Features

- 01 Maximum energy harvest
- 02 Automatic dual mode operation
- 03 Cloud-based performance monitoring for each panel
- 04 Quick and easy installation
- 05 Safe AC operation with no high-voltage DC
- 06 No single-point of failure
- 07 Best-in-class reliability
- 08 Remote Updates and Configurable Settings
- 09 75% reduction in cable costs

Model: Q2000-4102
Single-Phase



Technical Specifications

Input (DC) Specifications		
DC Input Power	W	2000
Number of channels		4
PV Panel Rating Module (STC)	W	Up to 680 Wp per channel
Maximum Input DC Current	A	16 per channel
Full Power MPPT Voltage Range	V	34 - 45 per channel
Extended MPPT Voltage Range	V	20 - 60 per channel
Start-up Voltage	V	19 per channel
DC Connection Type		MC4 compatible panel receptacles

Output (AC) Specifications		
Grid Connection Type		230V L-N from 1- ϕ
Operational Voltage Range	V	184 - 276
*Maximum Continuous Power	W	2000 @ 60°C
Nominal Output Frequency	Hz	50
Operational Frequency Range	Hz	47.5 – 52.5 default
		Extendable according to various standards
Power Factor		> 0.99 default. Programmable from 0-0.99 leading/lagging
Output THD	%	< 2, default
Inrush Current	A	< 8
Output Wiring Type		14 AWG
Output Connection Type		T5 AC micro male connector 98053

Safety and Protection		
Input Reverse Voltage Polarity Protection		Yes, Polarized PV Connectors
Anti-Islanding Protection		Yes, programmable to meet various standards UL1741, UL1741 SA, Rule 21, IEC
Integrated GFDI		Yes
Isolation		Galvanic isolation
Abnormal Voltage/ Frequency Trip Time		Less than 200ms

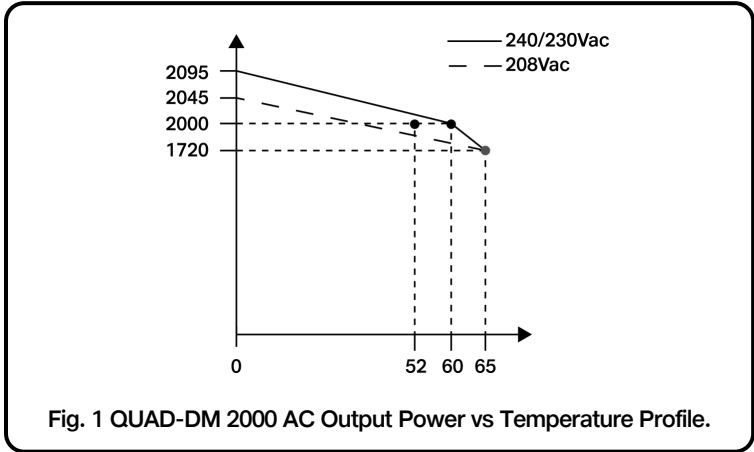

Fig. 1 QUAD-DM 2000 AC Output Power vs Temperature Profile.

AC Output - OFF-Grid		
Operational Voltage Range	V	90-245
Nominal Output Frequency	Hz	55
Operational Frequency Range	Hz	54-56

Regulatory		
Regulatory Certifications		UL1741, UL1741 SA/Rule 21/ HECO/Rule 14H, IEEE1547, IEEE1547.1, CSA22.2 No. 107.1, FCC Part 15-Class B, IEC 60068-2(1,2,14,30), IEC 62109-1/2, IEC 61727, IEC 61000-6-1/ 6-3, IEC 61000-3-2/ 3-2, IEC61683, IS 16221 (PART 2), IS: IS16169

Efficiency and Operating Performance		
Maximum Efficiency	%	97.5
CEC Efficiency	%	97
MPPT Efficiency	%	Static: 99.85 – Dynamic: 99.8
Stand-by Consumption	mW	<30

Communication		
Monitoring System		Wireless, Web-based monitoring

Environmental		
Ambient Operating Temperature	°C (°F)	-40 to +65 (-40 to +149)
Relative Humidity	%RH	0 – 100 condensing

Mechanical		
Enclosure Rating		NEMA 6, IP-67
Cooling		Natural Convection
Dimensions (D x W x L)	mm (in)	32 x 261 x 357 (1.25 x 10.3 x 14.0)
Weight	kg (lb)	3.3 (7.3)
Recommended Mounting		Rack mount with two M8, 1/4", or 5/16" bolts

Warranty		
Standard Limited Warranty		12 years
**Extended Warranty		25 years

Configurable Smart Grid Parameters		
Voltage Ride through	Under Voltage	Maximum 4 levels with Programmable ride-through time
	Over Voltage	Maximum 3 levels with Programmable ride-through time
Frequency Ride through	Under Frequency	Maximum 6 levels with Programmable ride-through time
	Over Frequency	Maximum 4 levels with Programmable ride-through time
Reconnect Time		Programmable wait time of 0-5 minutes
Power Ramp Rate		Programmable on both active and reactive power

*For higher ambient temperature, please refer to the graphs shown in Fig. 1.

**Please reach out to company for more information



Mechanical Specifications (Inverter)

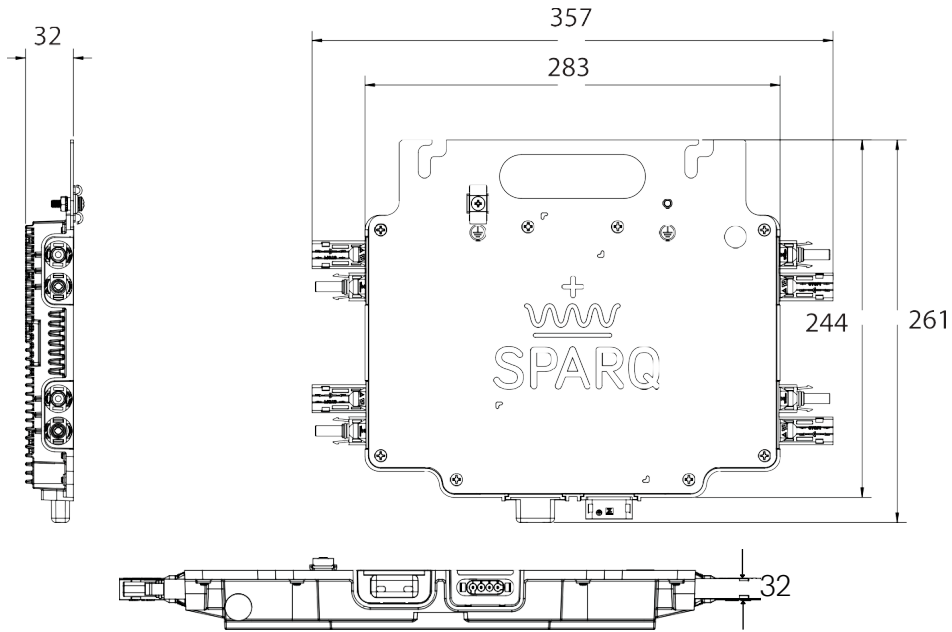

Mechanical Specifications (Cables)

Ti-Lane T5 free connector female 65069-13

PIN1	Empty
PIN2	L: Brown
PIN3	Empty
PIN4	N: Blue

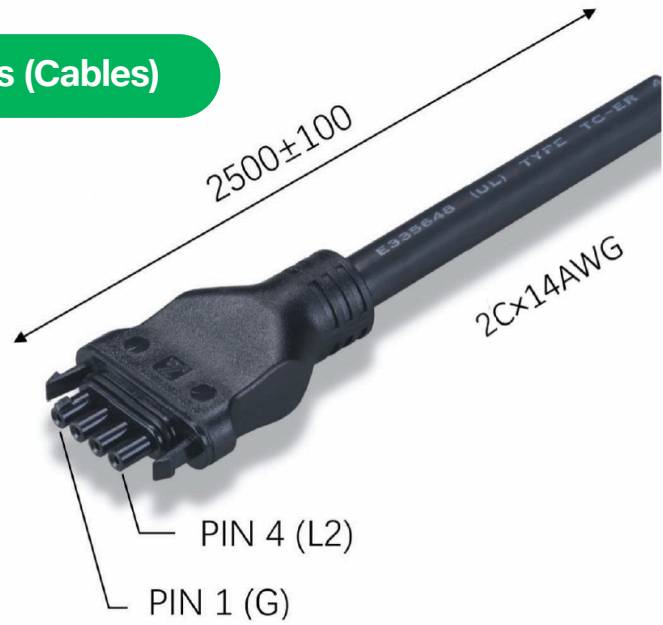

AC Cable from T5 female to open, 2C, AWG 14

Region	Conduct Number	Color Code	Length	Ti-lane P/N
India/Europe	2C	L1:Brown; Neutral:Blue	2m	65069-11
India/Europe	2C	L1:Brown; Neutral:Blue	2.5m	65069-13
India/Europe	2C	L1:Brown; Neutral:Blue	4m	65069-12

All dimensions in mm

Model: Q2000-4102
Single-Phase

